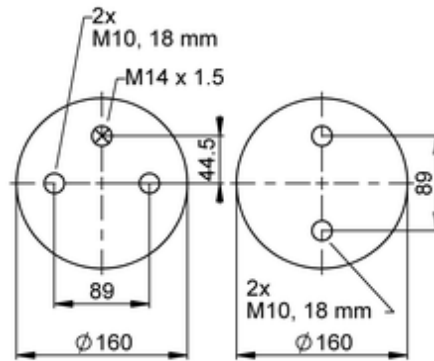
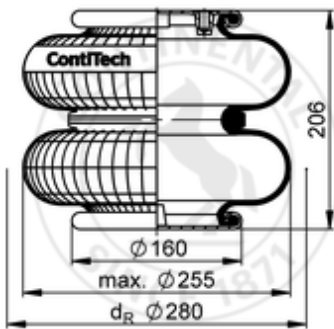

FD 200-19 M14 M10
53863

bolt or stud
 hole
 combination stud
 air inlet
 stud and nut

kg	3,1 kg
	M10: max. 40 Nm
	M14x1.5: max. 20 Nm

OE Manufacturer/Part No.

Manufacturer	Original Part No.	Model
Scania	1863244	