

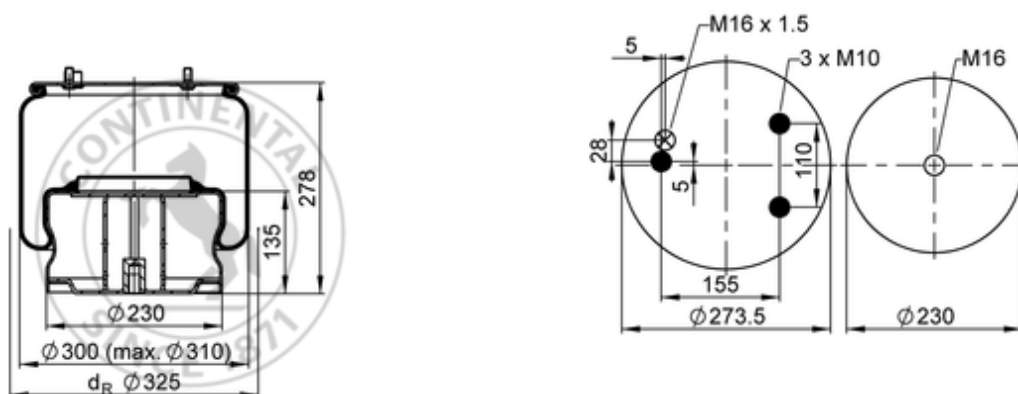











836 M K7

60278



 bolt or stud
  hole
  combination stud
  air inlet
  stud and nut

 kg	7,3 kg
	K008
	
	M10: max. 35 Nm
	M16: max. 130 Nm
	M16x1.5: max. 40 Nm

OE Manufacturer/Reference No.

Manufacturer	Original-part no.	Model
DAF	0 297 721	