

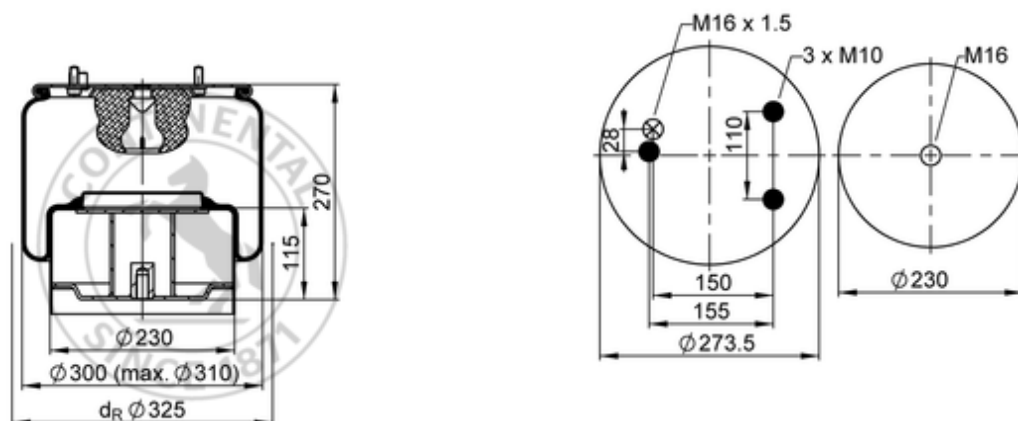







836 MB K4

60276



 bolt or stud
  hole
  combination stud
  air inlet
  stud and nut

| | |
|--|---------------------|
|  kg | 10,1 kg |
|  | K008 |
|  | |
|  | M10: max. 35 Nm |
|  | M16: max. 130 Nm |
|  | M16x1.5: max. 40 Nm |

OE Manufacturer/Reference No.

| Manufacturer | Original-part no. | Model |
|--------------|-------------------|-------|
| VDL Bus | 0 377 498 | |