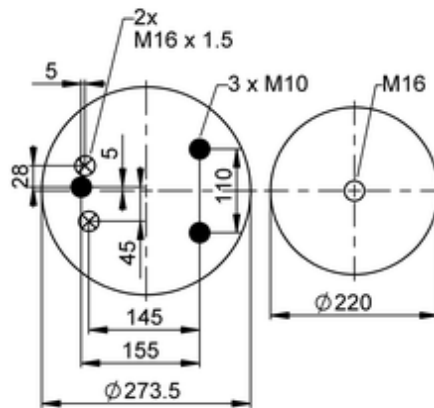
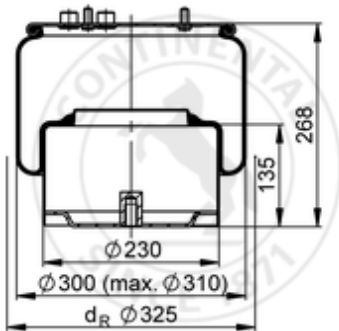

836 M2 K1
60210

- bolt or stud
- hole
- combination stud
- air inlet
- stud and nut

	9,1 kg
	K008
	M10: max. 35 Nm
	M16: max. 130 Nm
	M16x1.5: max. 40 Nm

OE Manufacturer/Part No.

Manufacturer	Original Part No.	Model
DAF	0 388 167	