

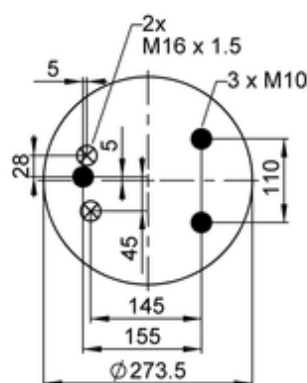

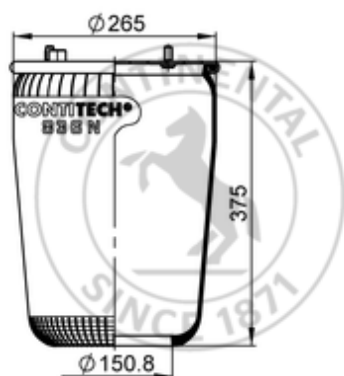

836 M2

60280



bolt or stud
 hole
 combination stud
 air inlet
 stud and nut

 kg	4,4 kg
	K008
	M10: max. 35 Nm
	M16x1.5: max. 40 Nm

OE Manufacturer/Reference No.

Manufacturer	Original-part no.	Model
DAF	0 513 982	
VDL Bus	0 513 982	