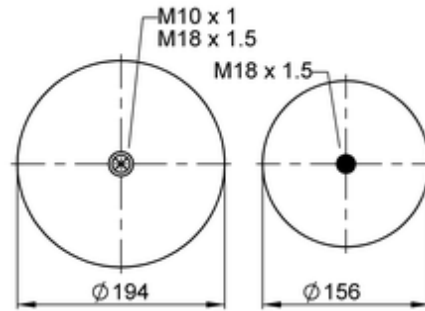
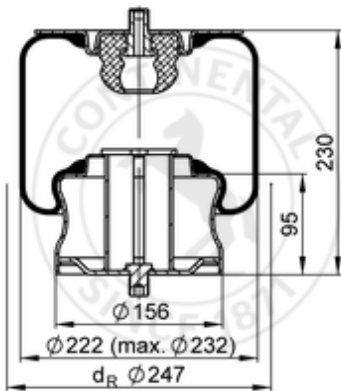

819 MB
67196

- bolt or stud
- hole
- combination stud
- air inlet
- stud and nut

	4,8 kg
	M18x1.5: max. 80 Nm

OE Manufacturer/Part No.

Manufacturer	Original Part No.	Model
Paul NFZ	A 667 328 01 01	Transporter
Mercedes	A 667 328 01 01	Vario. T0
Temsa	TM260133Y	Opalin