

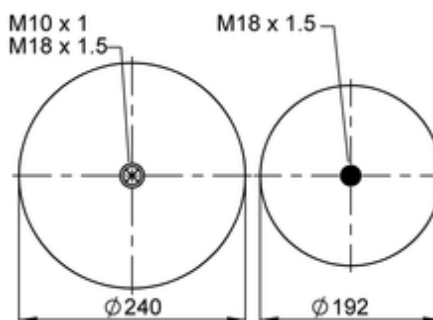

817 MB

73426

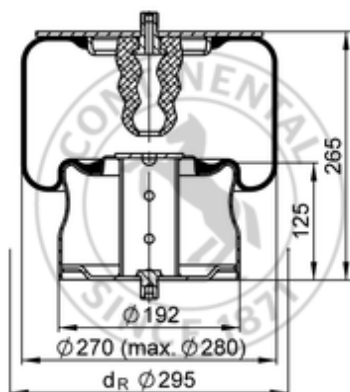

-  bolt or stud
-  hole
-  combination stud
-  air inlet
-  stud and nut

	7,8 kg
	M18x1.5: max. 80 Nm

### OE Manufacturer/Reference No.

Manufacturer	Original-part no.	Model
IRISBUS	5.000.786.641	100 V8
IRISBUS	5.810.111.355	A 320
IRISBUS	5.000.786.641	100 V8
IRISBUS	5.810.111.355	A 320
Otokar	16L00-03650-AA	