

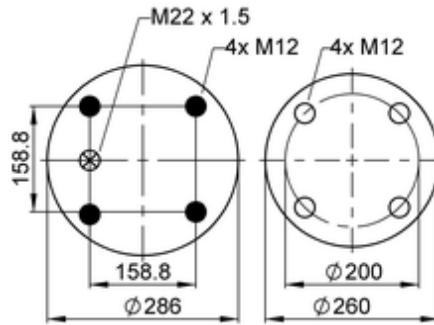

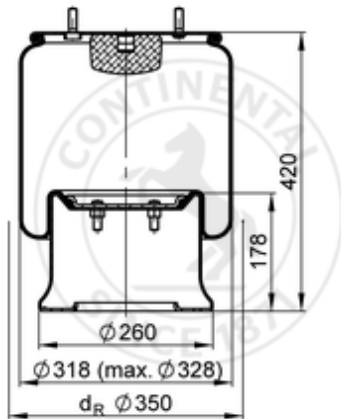



813 MB

67193



bolt or stud   
  hole   
  combination stud   
  air inlet   
  stud and nut

	13,2 kg
	K002
	
	M12: max. 70 Nm
	M22x1.5: max. 20 Nm

### OE Manufacturer/Part No.

Manufacturer	Original Part No.	Model
Paul NFZ	P2700MB0813	
SAE	8403 / 102	
Trouillet	ST 225-675	
Titan	916 8770 0000	
Trailer	003 6158 E	
Trailer	6502 3482	
Viberti	128 147 122	

Viberti	644 285	
Weweler	US 87408	
Weweler	US 07345	
Kässbohrer	4.731.030.000	
Kässbohrer	4.731.033.000	
Hendrickson	785 170	
Granning	15634	
SAF - Holland	2923	
Meritor	2121 5633	
Scania	1723269	
Renault	5.010.130.925	
SAF - Holland	2.229.0010.00	
Renault	5.000.790.692	
SAF - Holland	2.229.2103.00	2923 AR 211-213. AR 413
SAF - Holland	2.229.2403.00	2923 AR 211-213. AR 413
SAF - Holland	2.229.2603.00	2923 AR 211-213. AR 413
SAF - Holland	2.229.0003.00	2923 AR 211-213. AR 413
SAF - Holland	2.229.0003.00	2923 R 112-113. R 142-143
Hendrickson	505 859	Airpoise <'86
Hendrickson	505 859 / 01	Tecair
Pegaso	175005	Troner