

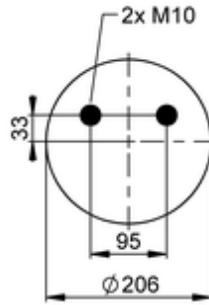

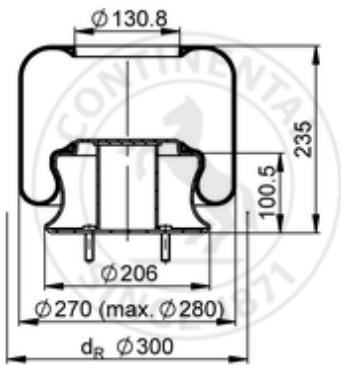





6621 N P02

53884



-  bolt or stud
-  hole
-  combination stud
-  air inlet
-  stud and nut

	4,2 kg
	M10: max. 40 Nm

**OE Manufacturer/Part No.**

Manufacturer	Original Part No.	Model
Volvo	20 535 877	B6BLE/ B7L/ B7R/ B9S/ B10B/ B10L