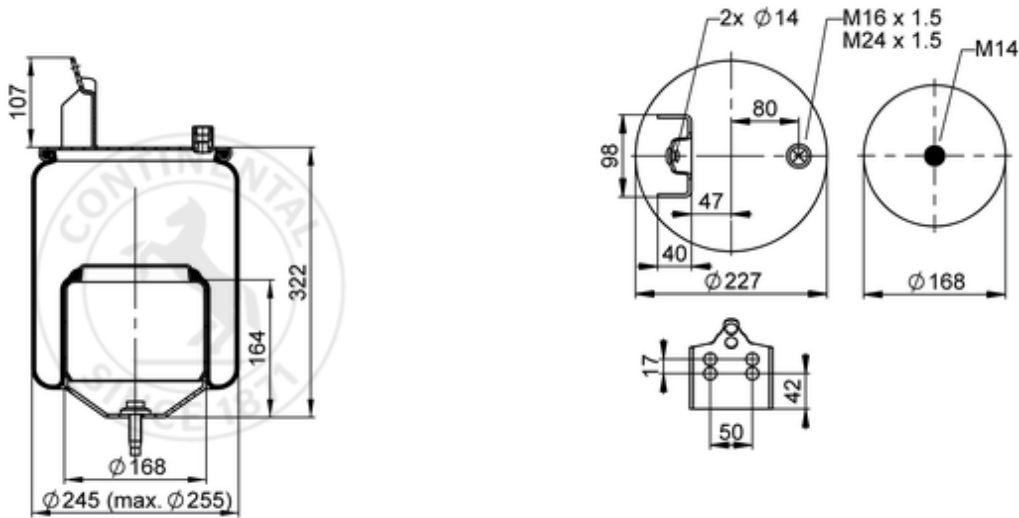

6608 N P01
63371

bolt or stud
 hole
 combination stud
 air inlet
 stud and nut

kg	5,6 kg
	K005
	M14: max. 120 Nm
	M16x1.5: max. 20 Nm
	M24x1.5: max. 60 Nm

OE Manufacturer/Part No.

Manufacturer	Original Part No.	Model
Renault	7.422.071.639	
Volvo	20 374 510	FH 12
Volvo	20 456 152	FH 12
Volvo	1 075 891	FH 12
Volvo	1 076 416	FH 12

Volvo	20 531 985	FH 12
Volvo	21 961 456	FM / FH standard
Volvo	20 582 215	FM / FH standard