

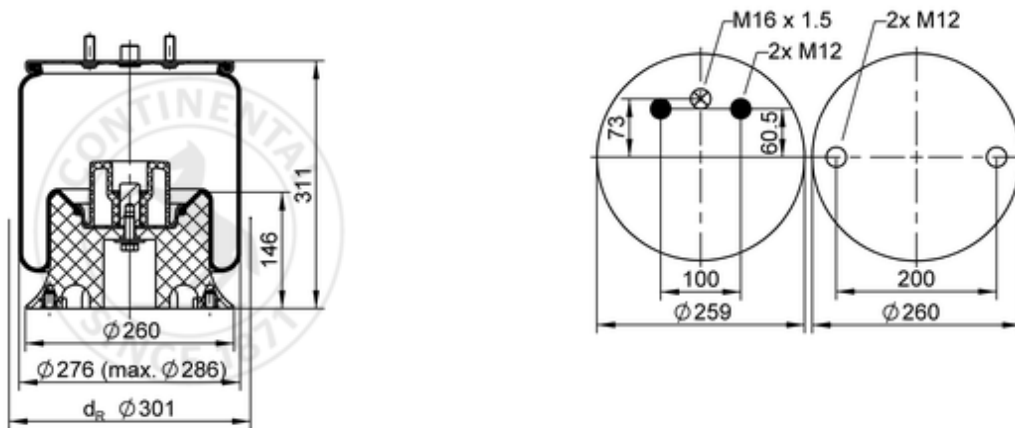









4927 N P01

70549



 bolt or stud
  hole
  combination stud
  air inlet
  stud and nut

 kg	6,5 kg
	
	M12: max. 40 Nm
	M16x1.5: max. 80 Nm

OE Manufacturer/Part No.

Manufacturer	Original Part No.	Model
Volvo	22 025 612	
Volvo	25 379 286	
Volvo	20 722 409	
Renault	5.010.305.391	Midlum <16t
Renault	22 025 580	Midlum <16t
Renault	5.010.630.800	Midlum <16t
Renault	7.422.025.580	Midlum <16t

