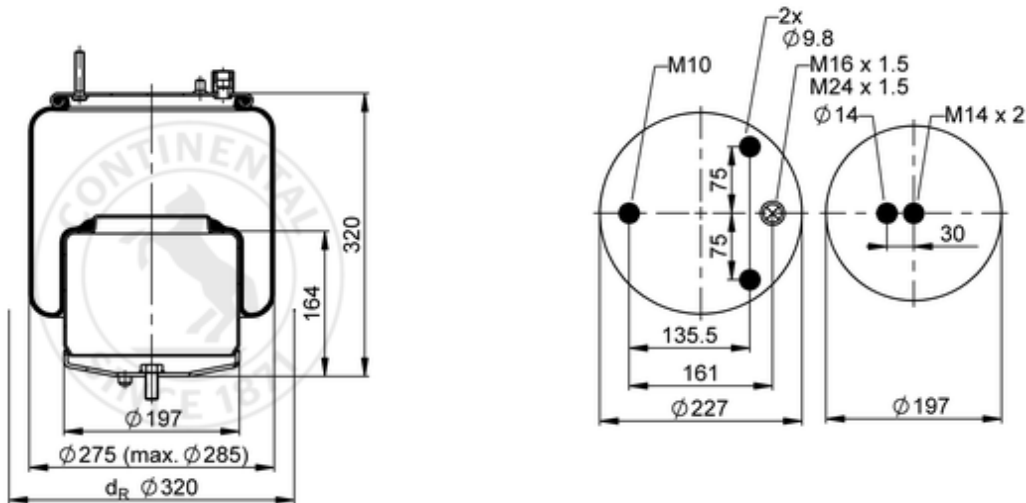

4560 N P02
75758

bolt or stud
 hole
 combination stud
 air inlet
 stud and nut

kg	6,7 kg
	M10: max. 40 Nm
	M14: max. 120 Nm
	M16x1.5: max. 20 Nm
	M24x1.5: max. 60 Nm

OE Manufacturer/Part No.

Manufacturer	Original Part No.	Model
Volvo	22 058 737	Volvo FM / FH
Volvo	21 224 745	Volvo FM / FH